

WATER QUALITY MONITORING AT THE KERN RIVER FIELD

Dale F. Brost PhD

Biographical Sketch of Author

Dale F. Brost received his BS degree in Chemistry from Loyola University of Los Angeles in 1973, and his PhD in Chemistry from Baylor University in 1978. He joined Texaco Inc. in 1979, and divided the next 22 years equally between research and field assignments dealing with various aspects of oilfield chemistry. Since 1989, he has specialized in the development and field application of water quality monitoring instrumentation. In 1997, he was a Distinguished Lecturer for the Society of Petroleum Engineers, speaking on the topic *Monitoring and Control Systems for Produced Water*. Dr. Brost is currently employed by ChevronTexaco in Bakersfield, California.

Abstract

Approximately 470,000 BWPD of produced water from the Kern River Field is used to irrigate crops in California's San Joaquin Valley. A variety of laboratory methods and on-line analysis instruments are used to track oil-in-water levels inside the water plant and to verify water quality at the plant discharge.

The *Environmental Oil Alert System* (EOA, Houston Photonics Inc.) is a dual-stream, process fluorometer used to monitor dispersed oil concentration in the 0-10 mg/L range. Each instrument is fed by a water stream that is conditioned with a surfactant and a high-shear pump. The surfactant/pump combination converts the large droplets of heavy oil into a translucent microemulsion that is suitable for fluorescence analysis. These instruments are installed at the outlets of 12 flotation cells. The on-line results are used to automatically control the dosage of a polymer water clarifier, injected upstream of each flotation cell.

Water discharged to the environment is monitored by an *OMD-7 Water Quality Monitor* (Deckma Hamburg GmbH.). This is a light-scattering instrument that simultaneously reports dispersed oil, suspended solids and turbidity. The results are used to alarm operators if effluent water quality begins to degrade.

A simple, solvent-free lab method is used for the determination of dispersed oil in produced water samples (20-1200 mg/L). Oily water samples are treated with the EOA surfactant and analyzed by UV/VIS absorption spectroscopy. Plant technicians use the method to rapidly measure total dispersed oil and residual suspended oil (oil that doesn't float in 5 minutes) upstream of the flotation cells. Results are used to optimize the operation of separation tanks, and to forecast impending problems from reverse emulsions.

WATER QUALITY MONITORING AT THE KERN RIVER FIELD

Dale F. Brost PhD

Kern River Production

The Kern River Field, operated by ChevronTexaco, is located near the city of Bakersfield in Southern California's San Joaquin Valley. The field was discovered in 1899, and has been under steam flood operations since 1964. Current oil production is 100,000 BOPD (13°API) and 800,000 BWPD from more than 8,000 wells completed in thermally stimulated zones. Approximately 110,000 BWPD of interdiction water is produced from zones that have not yet been exposed to steam, as part of an experimental de-watering project. Both water sources are fresh, with total dissolved solids less than 800 mg/L. Selected water properties are listed in Table 1.

Property	Produced Water	Interdiction Water
Temperature ¹	160°F	95°F
Salinity	739 mg/L	275 mg/L
Total Hardness	86 mg/L CaCO ₃	84 mg/L CaCO ₃
Water Soluble Organics (WSO) ²	5.4 mg/L	0.4 mg/L
Relative WSO Fluorescence ³	22	1

¹Flotation cell outlet

²WSO = Total Oil & Grease – Total Petroleum Hydrocarbons (EPA Method 1664)

³?_{excitation} = 390 nm, ?_{emission} = 410 nm

Table 1. Selected Kern River water properties.

Station 36 Oil Dehydration and Water Cleaning Plant

All Kern River produced fluids are processed at Station 36. A simplified schematic is shown in Figure 1.

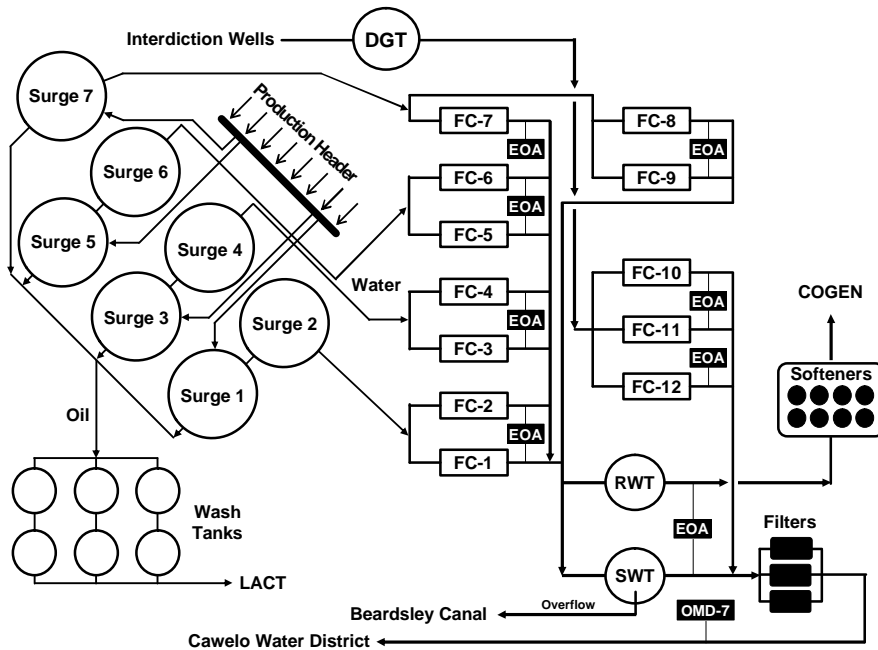

Figure 1. Station 36

Produced fluids are chemically treated with emulsion breakers before arriving at Station 36. The production header divides the flow from different areas of the field between four primary surge tanks (Surge 1, 2, 3 & 7). Oil that rises to the top of the primary surge tanks flows to a series of heated wash tanks. Water from the bottom of Surge 1, 2 and 3 flows to three secondary surge tanks (Surge 2, 4 & 6). A polymer water clarifier is injected at the inlet to the secondary surge tanks. Gas is withdrawn from the head space of these tanks and educted into the inlet water stream to assist with oil/water separation. Additional oil is skimmed from the surface of the secondary surge tanks and sent to the wash tanks. A secondary surge tank for Surge 7 is currently under construction. Gas is removed from the head space of all seven surge tanks by a vapor recovery system.

Water from Surge 2, 4, 6 and 7 flows to nine induced gas flotation cells (FC-1 – FC-9), each with a capacity of 150,000 BWP. A polymer water clarifier is added to each flotation cell inlet, at a dosage determined by a process control system. Produced water cleaned by the flotation cells is then distributed between two suction tanks (Raw Water Tank, RWT and Surplus Water Tank, SWT). Water from the Raw Water Tank (~350,000 BWP) is softened and shipped to cogeneration facilities, which convert the water to steam and produce electric power. The remaining produced water flows to the Surplus Water Tank.

Interdiction water is treated with a polymer water clarifier before entering Station 36. The treated water flows through a tank (DGT) designed to skim oil and remove gas. The water is then purified by up to three flotation cells (FC-10 – FC-12). Each flotation cell has a capacity of 150,000 BWP. The number of flotation cells in service depends on the interdiction water rate, which can vary between zero and ~300,000 BWP. After passing through the flotation cells, the interdiction water is mixed with produced water at the outlet of the Surplus Water Tank. The variable mixture of produced water and interdiction water (~470,000 BWP) is then pumped through walnut shell filters to the Cawelo Water District, to be used for irrigation and aquifer recharge. If water rates are greater than the capacity of the Cawelo pipeline (600,000 BWP), excess produced water overflows from the Surplus Water Tank to the Beardsley Canal. This water is also used for irrigation in the San Joaquin Valley.

Effluent water from Station 36 can be safely discharged to the environment as long as the dispersed oil content remains below 2 mg/L. Experience has shown that above 2 mg/L, the dispersed oil has a tendency to form a visible sheen on the surface of standing water. If the water system becomes upset for any reason, it can be diverted in whole or in part to a 250,000 BBL recycle tank located outside of Station 36. After the upset, the diverted water is pumped back to the primary surge tanks for reprocessing as conditions permit.

Water Quality Monitoring - Overview

Two different on-line analyzers are used to monitor water quality at Station 36, the Environmental Oil Alert (EOA) and the OMD-7 Water Quality Monitor. The analyzer locations are shown in Figure 1.

The Environmental Oil Alert System (EOA) is installed at the outlet of each flotation cell. At these locations, the dispersed oil concentration, reported by the EOA, is used to alert operators of upsets, and to automatically regulate the dosage of water clarifier polymers. An EOA is also installed at the outlets of the Surplus Water Tank and Raw Water Tank, to monitor water quality feeding the filters and softeners. The OMD-7 Water Quality Monitor is installed at the main outlet of the plant, to provide a final measure of the water quality discharged to the Cawelo Water District. The reason for two different on-line analyzers will be explained later in this paper.

Upstream of the flotation cells, where dispersed oil concentration can be hundreds of mg/L, operators use a solvent-free laboratory method to monitor water quality. The method is used to measure dispersed oil and residual suspended oil (dispersed oil that doesn't float in 5 minutes). This information is used to track and optimize the oil/water separation performance of the secondary surge tanks, and to provide early warnings of system upsets from reverse emulsions.

Environmental Oil Alert System (EOA)

The EOA is a modular, process fluorometer that is capable of simultaneously monitoring the dispersed oil content of two separate water streams. It was developed by the author's research group at Texaco Inc.¹, and is currently manufactured by Houston Photonics Inc.² As illustrated in Figure 2, the instrument consists of a photometry module that is optically linked to two falling stream chambers by fiber optic cables.

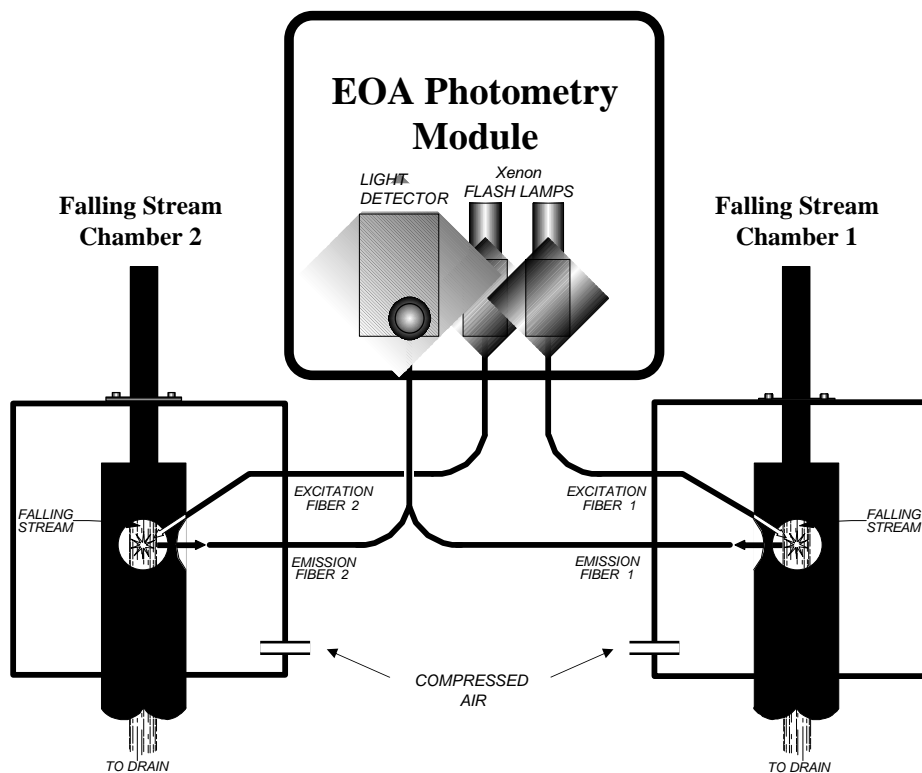

Figure 2. Schematic diagram of the EOA System.

The falling stream chamber is designed to allow light beams to interact directly with an unconfined stream of water as it falls through air. Because there are no optical surfaces between the light beams and the water stream, the EOA is not susceptible to the fouling problems that plague “flow-cell” optical analyzers. Also, a gentle stream of compressed air is applied to the falling stream chamber to prevent water vapor from condensing on the lenses. Experience at Kern River has shown that this design works effectively at water temperatures up to ~170°F.

The photometry module generates intense pulses of excitation light from two xenon flash lamps. The photometry module also measures the intensity of the fluorescent light emitted by the oily water streams. Excitation and emission wavelengths are set with optical filters and can be specified by the user. Wavelengths are selected to yield the required sensitivity to oil, while discriminating against non-oil fluorescent substances such as corrosion inhibitors, reverse emulsion breakers, etc. Optimum performance at Kern River is obtained by exciting oil fluorescence at 390 nm (10 nm bandpass filter) and measuring the fluorescent emissions at 410 nm and up (long pass filter). This combination makes it possible to detect dispersed oil concentrations as low as 0.05 mg/L, without interference from water treating chemicals at 10X their normal levels.

¹ Brost, D., *et al.*: “Optical Photometry System for On-line Analysis of Fluid Systems”, U.S. patent 5,418,614 (1995).

² Houston Photonics, Inc., 10408 Rockley Road, Houston, TX 77099, (281) 564-6500

Kern River crude oil has a gravity of 13°API, is black in color, and contains a high concentration of fluorescent compounds (polynuclear aromatic hydrocarbons, asphaltenes, etc.). As shown in Table 1, the produced water contains 5.4 mg/L of highly fluorescent water soluble organic compounds (primarily naphthenic acids). The interdiction water also contains fluorescent water soluble organic compounds, but at a much lower concentration, 0.4 mg/L.

As mentioned above, Kern River crude oil is highly fluorescent, and can be easily detected at low part-per-billion ($\mu\text{g/L}$) levels when dissolved in a non-fluorescent organic solvent. However, early field trials with on-line fluorometers at Station 36 revealed that the oil could not be detected at part-per-million (mg/L) levels when dispersed in water. The particle sizes created by the shear conditions at Station 36 are too large to allow significant interaction between the excitation light and the dispersed oil. The vast majority of oil molecules are located inside the oil droplets, where they are shielded from the excitation beam by an optically dense surface, and cannot be stimulated to emit fluorescent light. Microscopic analysis showed that when dispersed oil was present at 5 mg/L, the oil particle diameters varied from 5 to 100 microns. Under these conditions, virtually all of the detected fluorescence came from the water soluble organic compounds.

The dispersed oil sensitivity problem was solved by the addition of a non-fluorescent surfactant to the water stream on its way to the falling stream chamber. When the surfactant contacts dispersed oil, it converts the oil into a translucent microemulsion that is suitable for fluorescence analysis. The most effective surfactant was found to be Surfonic L24-9, a C12-C14 linear alcohol with 9 moles of ethylene oxide (Huntsman Chemical Company). The neat surfactant is a waxy solid at room temperature. A liquid blend is prepared that contains 30 wt% Surfonic L24-9, 25 wt% acetic acid and 45 wt% distilled water. The acetic acid facilitates dissolution of the surfactant, and keeps the product stable at low ambient temperatures. The final blend is injected into the sampled water stream at a bulk concentration of $\sim 700 \mu\text{L/L}$ ($\sim 210 \text{ mg/L}$ active surfactant). Tests run by dissolving the surfactant blend in distilled water revealed that the blend contributes no detectable fluorescent light when excited at 390 nm.

Figure 3 illustrates the effect of the surfactant addition on dispersed oil fluorescence. Fluorescence was measured by the EOA at the outlet of FC-9, while the dispersed oil content varied between 0.9 and 1.1 mg/L.

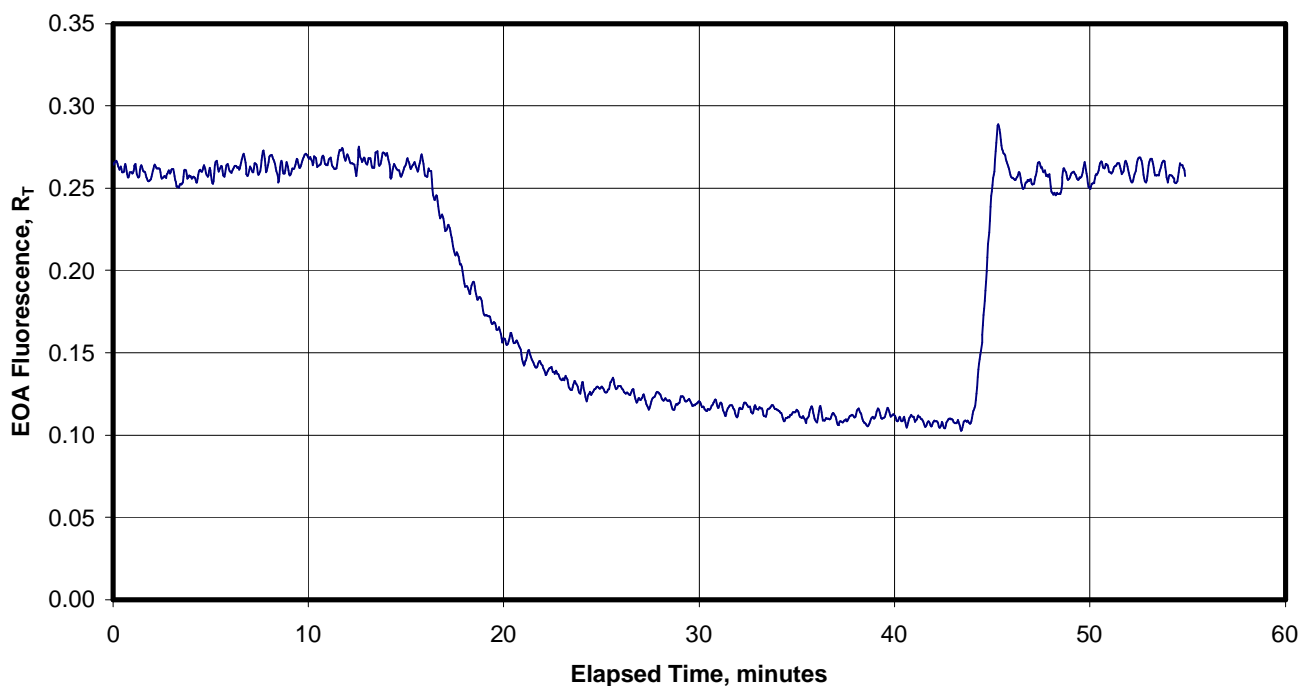

Figure 3. Effect of surfactant addition on dispersed oil fluorescence.

The surfactant blend was injected at a concentration of 700 $\mu\text{L/L}$ at the beginning of the test. After 16 minutes, the surfactant pump was turned off. Fluorescence intensity immediately began to drop as the residual surfactant was purged from the soak tube (see below). After 43 minutes, the surfactant pump was turned back on. Dispersed oil fluorescence was restored 2 minutes later, when surfactant-treated water again reached the falling stream chamber. The surfactant technology described here was developed and patented by Texaco Inc. and licensed exclusively to Houston Photonics Inc.³

During normal monitoring with the surfactant pump running, both solubilized dispersed oil and water soluble organic compounds contribute to the total fluorescence measured by the EOA.

$$R_T = R_D + R_{WSO} \quad (1)$$

where: R_T = Total fluorescence

R_D = Fluorescence from solubilized dispersed oil

R_{WSO} = Fluorescence from water soluble organic compounds

A typical EOA installation is shown in Figure 4.

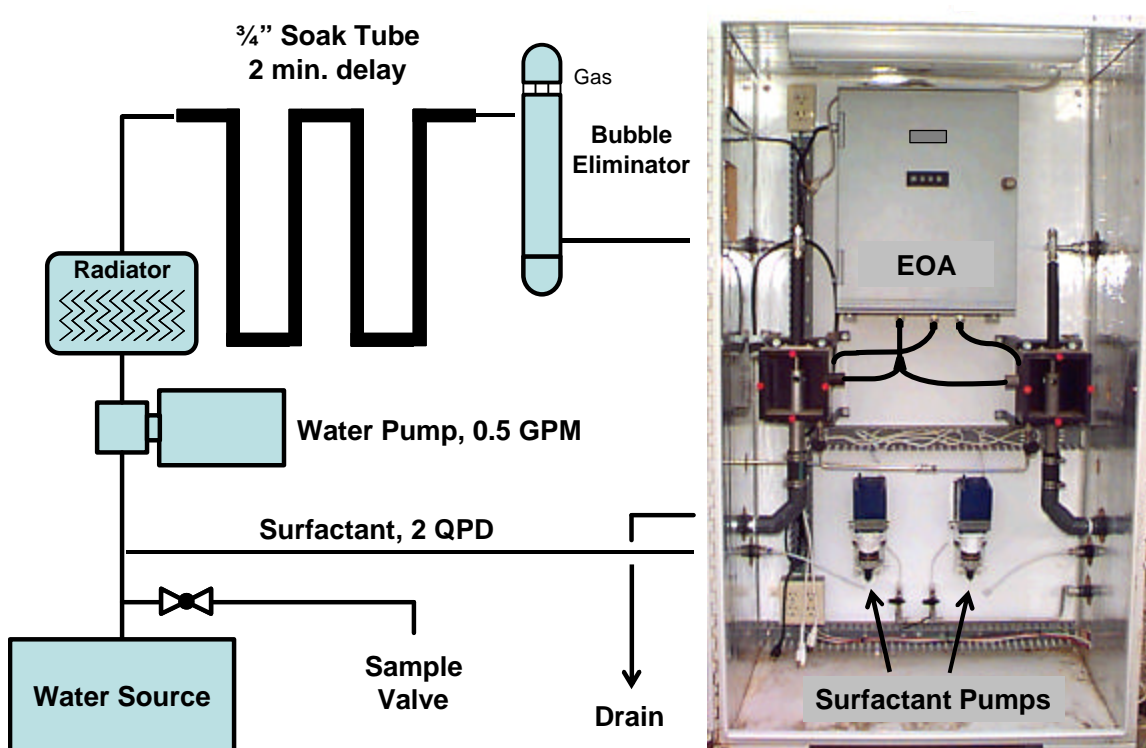

Figure 4. Typical EOA installation.

Water is pumped from the sample port to the falling stream chamber at a rate of 0.5 gallons per minute, by a high-shear, 3-stage, centrifugal pump operating at 3500 RPM. The surfactant blend is injected at 2 quarts per day into the sampled water stream as soon as it leaves the system. The water stream then flows through a forced-air radiator. The radiator cools the water stream below the cloud point of the surfactant ($\sim 160^\circ\text{F}$) to avoid secondary fluorescence effects from light scattering. It is necessary only in the summer, when water temperatures often reach 165°F . The water then enters a soak tube, which is a length of $3/4$ " tubing with an internal volume of ~ 1

³ Morrow, L., *et al.*: "Fluorescence Method of Quantifying Hydrocarbons, Including Crude Oil Dispersed in Water", U.S. patent 5,381,002 (1995).

gallon. This provides a delay of ~2 minutes to allow the surfactant time to solubilize the oil before the water stream reaches the falling stream chamber. To prevent errors from gas bubbles, the water flows through a bubble eliminator immediately before entering the falling stream chamber. After the fluorescence measurement is complete, the water enters a drain and is pumped back to the inlet of the plant.

EOA Calibration

The EOA converts fluorescence response, R_T , to dispersed oil concentration, C , using the 2nd order polynomial function shown in Equation 1.

$$C = a + bR_T + cR_T^2 \quad (2)$$

The calibration constants, a , b and c , are determined by a least-squares regression relating measured R_T values to known dispersed oil concentrations.

Best results are obtained when the calibration data comes from samples collected from the water line feeding the EOA. Samples containing varying concentrations of dispersed oil are collected upstream of the surfactant injection point. When the water system is unstable, an adequate range of oil concentration can usually be encountered in a few hours. However, when the water system is stable, and oil concentration is not changing naturally, varying oil concentrations can be created by adjusting flotation cell parameters (polymer rate, water level, agitator speed, etc.).

The dispersed oil content of each sample is determined colorimetrically after extracting the oil into TCE. The extraction is performed without acidifying the water sample, in order to leave the water soluble organic acids in the aqueous phase, thereby excluding them from the dispersed oil result. The water sample must be taken upstream of surfactant injection, because the surfactant “holds” some of the solubilized dispersed oil in the aqueous phase, preventing it from being extracted into the TCE. R_T is measured by the EOA two minutes after the sample begins to flow into the sample bottle, and is averaged over the period required to fill the bottle. This accounts for the time required for the water stream to travel from the sample port to the falling stream chamber.

If no low concentration samples are available, it is possible to estimate the R_T value that corresponds to a dispersed oil concentration of 0 mg/L. This is done by turning off the surfactant pump and waiting for the incoming water to wash the residual surfactant out of the system (Figure 3). In the absence of surfactant, R_T is very close to R_{WSO} , because virtually no fluorescent light is emitted by the untreated dispersed oil (If $R_D \sim 0$, then $R_T \sim R_{WSO}$).

Typical calibration data is shown in Table 2. The corresponding graph is shown in Figure 5.

Date	R_T	Dispersed Oil Content, mg/L
3/21	1.425	1.5
3/21	0.811 R_{WSO}	0.0
3/21	1.793	3.4
3/21	2.515	6.2
3/21	3.291	11.2
4/17	0.932	0.3
4/19	1.543	1.5
4/24	1.737	2.6
4/30	1.587	2.2
5/7	1.204	0.9
5/9	1.152	0.7

Table 2. EOA calibration data – FC-5, produced water.

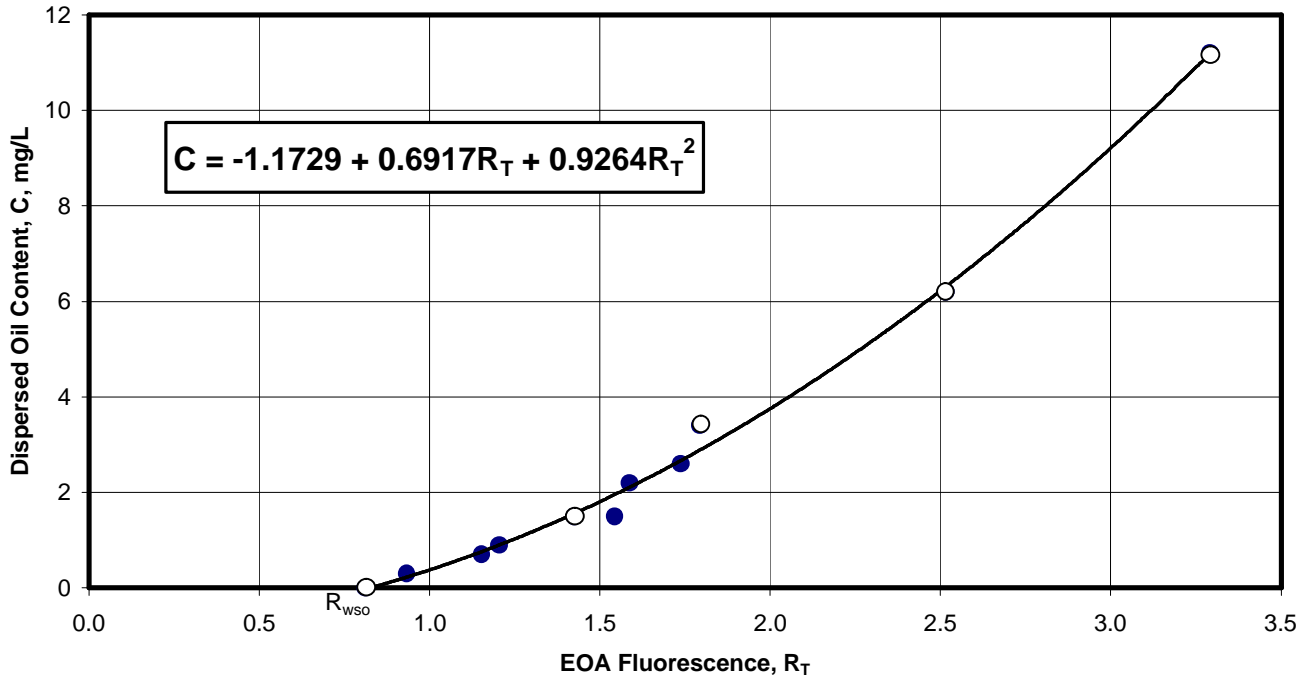

Figure 5. EOA calibration curve – FC-5, produced water.

As shown in Table 2, the data was collected over a period of ~6 weeks. The data collected on 3/21, which is plotted as open circles in Figure 5, was obtained by adjusting flotation cell parameters while the flotation cell effluent was diverted to the 250,000 BBL recycle tank. R_{WSO} was measured 30 minutes after turning off the surfactant, while the dispersed oil concentration was ~1.5 mg/L. The calibration equation shown in Figure 4 was established using only the data from 3/21. Subsequent calibration measurements are in good agreement, illustrating the stability of the system. Calibration curves for the interdiction water system are similar in shape, but have R_{WSO} values that are very close to zero. Experience has shown that, as long as the instruments are properly maintained, calibration functions usually remain valid for many months. When calibration drift does occur, it can usually be attributed to major shifts in fluid distribution at Station 36, and background fluorescence (R_{WSO}) changes as a result of migrating steam operations throughout the field.

EOA Maintenance and Quality Control

Routine maintenance is performed to keep the EOA systems in good working order. Twice a day, plant operators purge the soak tube with lease water to remove any solids, and open the falling stream chambers to check the water flow and inspect for condensation.

Quality control is performed once per week by a trained technician. Two tests are performed:

- EOA Sensitivity Test** – The sensitivity of the EOA is determined by the condition of the optical and electronic components of the photometry module, and by the transmission efficiency of the optics that carry light to and from the falling stream. In order for measurements to be accurate, the sensitivity of the EOA must be the same at the time of measurement as it was at the time of calibration. The EOA Sensitivity Test is a very simple means of verifying that this condition is true. The technician simply records the EOA fluorescence response, R_T , while filling a sample bottle with water from the falling stream drain. He then places the sample in a test tube and measures the fluorescence intensity, I , with a bench-top fluorometer that has been calibrated with a piece of fluorescent glass. Sensitivity is defined by the ratio of the two measurements, as shown in Equation 3.

$$\text{Sensitivity} = R_T/I \quad (3)$$

- **EOA Accuracy Test** – This test determines how closely the EOA result agrees with the dispersed oil concentration determined by the TCE extraction test. Samples are collected and analyzed using the same procedure described above for calibration. However, for this test, the EOA’s reported dispersed oil concentration is recorded, instead of the R_T value. Measurement error is computed according to Equation 4.

$$\text{Error} = \text{EOA Oil Concentration} - \text{TCE Oil Concentration} \quad (4)$$

Figure 6 shows quality control results over an 18 week period, while the dispersed oil concentration varied between 0.3 and 2.4 mg/L.

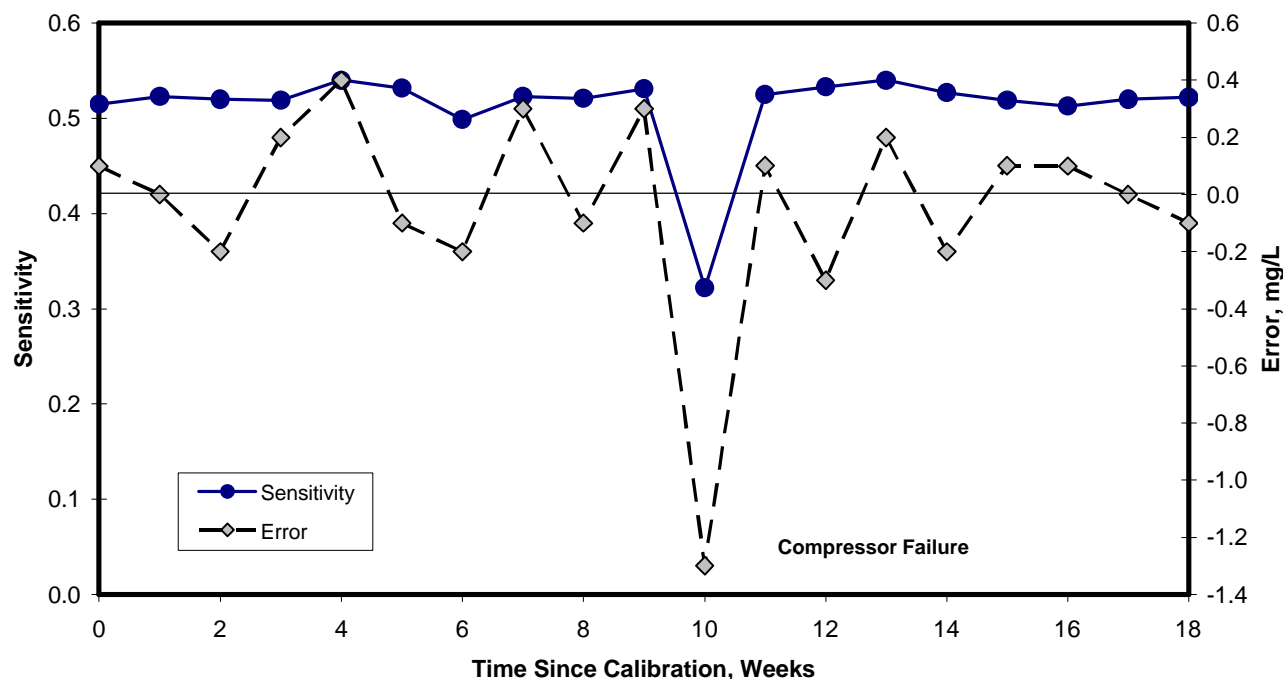

Figure 6. Example quality control results.

The QC results showed no significant change in sensitivity until 10 weeks after calibration. At that time, the air compressor failed, allowing steam to condense inside the falling stream chamber. This coated the lenses with water droplets, which severely reduced the amount of fluorescent light transmitted to the photometry module. As a result, the reported dispersed oil concentration was 1.3 mg/L low. After the lenses were dried and the compressor was repaired, the sensitivity and accuracy was restored.

The error data shown above indicates that the EOA dispersed oil result is usually within ± 0.3 mg/L of the TCE result, and that, with proper maintenance, this level of accuracy can be maintained for extended periods of time.

Automatic Polymer Dosage Control

EOA measurements are used to control the dosage of polymer water clarifier into each produced water flotation cell (FC-1 – FC-9, Figure 1). Every two seconds, the dispersed oil result is fed to the plant’s PLC system. The PLC compares the oil concentration to a set point (0.8 mg/L) and computes a new injection rate by a PID algorithm. Polymer concentration (bulk product) is allowed to vary between 0.5 and 2 $\mu\text{L/L}$. When oil

concentration is very low, polymer dosage is automatically reduced to the minimum to prevent waste. When oil concentration rises above the set point, polymer dosage increases to bring oil levels down.

Since its initial startup in 1993, this system has effectively maintained adequate polymer levels while plant operators were busy attending to other duties. However, it must be recognized that there are occasions when the dispersed oil concentration will be greater than the set point, but additional polymer will not help. The EOA measures total dispersed oil concentration only. It cannot detect if the oil is present in a form that requires polymer for flotation. Because of this, there have been occasions when the automatic control algorithm dosed the system with more polymer than was actually required. Two examples are described below.

- **Reverse emulsion is flowing through the plant.** This sometimes happens when emulsion treating chemicals get out of control, or excessive amounts of surfactants are used for well work, tank cleaning and softener resin cleaning. Under these conditions, the oil particles are stabilized in a reverse emulsion that the polymer cannot effectively treat. Polymer dosage goes up, but oil concentration never comes down to the set point.
- **Dispersed oil concentration is above the set point, but the oil particles are already large.** This happens as a result of flow surges, which bring slugs of dispersed oil into the flotation cell, effectively overloading its oil removal capacity. It can also happen when the flotation cell is not operating properly (improper skim levels, broken agitators, etc.). Under these conditions, the oil particles have already grown to sizes that float quickly, and additional polymer cannot improve the efficiency of the flotation cell. Once again, the process control system would increase the polymer dosage without yielding a benefit.

We are experimenting with a variety of process control algorithms designed to minimize polymer waste. The current scheme involves a periodic forced reduction in polymer dosage. Every two hours, if the EOA shows that effluent oil concentration is less than 2 mg/L, the PLC decreases the polymer dosage to the minimum level (0.5 $\mu\text{L/L}$). If the oil concentration begins to rise, the normal PID algorithm will increase polymer dosage within seconds before oil levels get too high. If the oil concentration does not rise, polymer dosage will increase more slowly, at a rate determined by the difference between the oil concentration and the set point. During periods when the oil is present in a form that polymer cannot treat, this scheme results in a polymer savings of approximately 50% over the PID algorithm alone.

Fluorescence Monitoring of Dispersed Oil -- Accuracy Limitations

With any fluorescence instrument, the accuracy of dispersed oil measurement is fundamentally limited by the relationship between the dispersed oil fluorescence and the stability of the fluorescent background. Best accuracy is obtained when the dispersed oil fluorescence is very intense and the fluorescent background is stable or negligibly small. Poor accuracy is obtained when the fluorescent background is unstable and comparable in magnitude to the dispersed oil fluorescence.

Equation 4 can be used to compute the concentration error that would result from a shift in R_{WSO} .

$$\% C = \% R_{\text{WSO}}(2cR_{\text{T}}+b) \quad (5)$$

where: $\% C$ is the concentration error for concentration C .

R_{T} is the fluorescence response measured for concentration C during calibration.

$\% R_{\text{WSO}}$ is the R_{WSO} shift.

b and c are the calibration constants from Equation 1.

Table 3 gives the concentration errors that would result at FC-5 from certain percentage shifts in R_{WSO} , while monitoring a dispersed oil concentration of 2.3 mg/L. Values for the calculation were taken from Table 2 and the calibration function in Figure 4.

R_{WSO} Shift, %	ΔR_{WSO}	Absolute Error ΔC , mg/L	Relative Error $100\Delta C/C$, %
0	0	0	0
5	0.041	0.1	6.4
10	0.081	0.3	12.8
20	0.162	0.6	25.6

$R_{WSO} = 0.811$, $R = 1.587$, $C = 2.3$ mg/L, $b = 0.6917$, $c = 0.9264$

Table 3. Effect of background fluorescence shifts on EOA accuracy.

The calculations show that, at a nominal value of 2.3 mg/L, the background fluorescence shift cannot be more than 10% for the dispersed oil concentration result to be within ± 0.3 mg/L of actual. This is not a problem at Kern River, as long as the EOA is applied to either the produced water system or the interdiction water system. However, the EOA cannot be used to monitor the final effluent of Station 36, where the two water systems are blended in widely varying proportions.

OMD-7 Water Quality Monitor

The OMD-7⁴ is a light scattering device. As such, it detects only the dispersed particles in the water stream, without interference from water soluble substances. We use this device at Kern River to monitor the final effluent of Station 36 as it is discharged to the Cawelo Water District (Figure 1).

As shown in Figure 6, the OMD-7 is composed of a computer module, a flow-cell based measurement module and a sample conditioning unit.



**Computer
Module**



**Flow-cell Measurement
Module**



**Sample Conditioning
Unit**

Figure 6. OMD-7 Water Quality Monitor

⁴ Deckma Hamburg GmbH, Kieler Strasse 316, 22525 Hamburg, Germany, +49 (0) 40 54 88 76 - 0

A schematic of the optical system is shown in Figure 8.

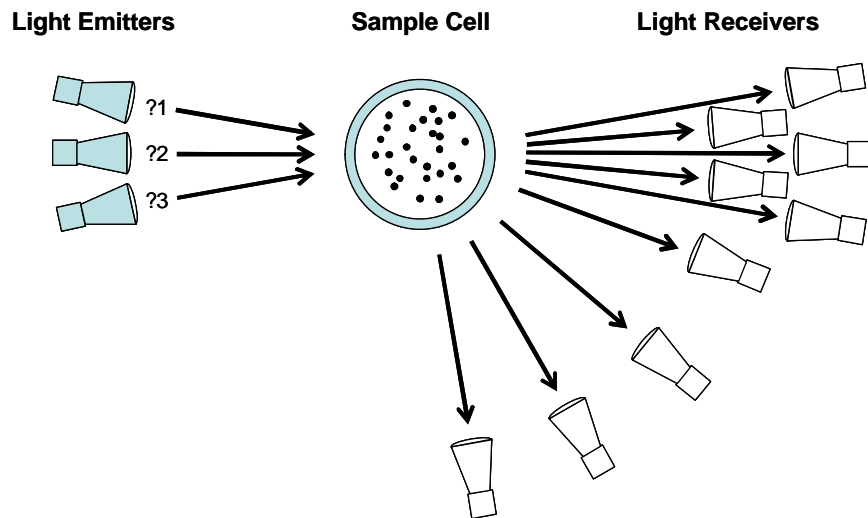

Figure 8. OMD-7 optical schematic.

Light emitted at three wavelengths is directed towards the sample cell at three incident angles. The particles in the sample cell scatter the incident light, resulting in three different scattered light distributions around the sample cell. In each distribution, the scattered intensity varies as a function of scattering angle. The scattered light is measured by nine light receivers positioned around the sample cell. Dispersed oil droplets and suspended solid particles produce different scattered light patterns. Proprietary algorithms convert the measured light signals to three different results, dispersed oil concentration (PPM), solids concentration (solids measurement units, SMU) and turbidity (FTU).

The instrument is calibrated by the manufacturer using either standard reference materials (oil & solid) or crude oil and suspended solids supplied by the user. Each measurement module requires its own calibration to compensate for optical irregularities in the glass sample cells. If a sample cell breaks, the measurement module must be returned to the manufacturer for repair and re-calibration. Calibration constants are supplied on a replaceable PC card that fits into the computer.

A pneumatic wiper assembly is supplied to keep the sample cell clean. The wiping frequency can be specified by the user.

The OMD-7 is normally calibrated to measure oil over a broad range (0-200 ppm). Because the effluent of Station 36 must be below 2 ppm for discharge to the Cawelo Water District, the manufacturer performed a special low-range calibration with Kern River crude oil to enhance performance in the 0-5 ppm oil range.

When the instrument was first installed, with a wiping frequency of once every 15 minutes, the sample cell became coated with oil and solids within a few hours. To place the instrument back in service, it was necessary to remove the wiper and brush the sample cell with a mixture of surfactant and hydrochloric acid to remove oil and precipitated iron compounds. Increased wiping frequencies did not help to extend the service interval.

The problem was solved by continuously injecting the EOA surfactant blend at a rate of 2 quarts per day into the water stream at the inlet of the sample cell. The surfactant blend, in conjunction with a wiping interval of once every 15 minutes, keeps the sample cell clean indefinitely. The only operational problem resulting from this approach is that the surfactant blend tends to swell the rubber wiper elements, making it necessary to change the elements once per week.

Calibration and analysis procedures given below are suitable for the determination of dispersed oil concentration from 20 to 1200 mg/L.

Calibration Procedure

1. Heat 485 mL of 30% Surfonic L24-9 (in distilled water) to 150°F in a 1 liter pyrex bottle.
2. Add 15 grams of LACT unit crude, and heat the mixture to near boiling while blending with a high-shear mixer (25,000 rpm tissue homogenizer). Stock Standard Oil Concentration = 30,000 mg/L.
3. Immediately prepare working standards spanning the concentration range of interest, by diluting the Stock Standard with distilled water. Add additional surfactant as required so that each working standard contains 20 mL of 30% Surfonic L24-9 per liter of solution.
4. Blend the standard with the high-shear mixer while heating it to the cloud point (~165°F). Allow the standard to cool until the cloudiness totally disappears.
5. Place the standard solution in a 10 mL syringe. Place a glass fiber pre-filter and a 0.2 micron cellulose acetate filter on the end of the syringe.
6. Dispense the standard into a glass cuvet with a path length of 1 cm.
7. Measure the absorbance of each standard versus a distilled water blank at a wavelength of 390 nm.
8. Create a calibration curve by plotting the concentration of the standard versus its measured absorbance.

Analysis Procedure

1. Sample: Add 20 mL of 30% Surfonic L24-9 to a graduated, 1 liter pyrex bottle. Carry the bottle to the sample site.
2. Swirl the bottle to coat the walls with surfactant.
3. Fill the bottle to the 500 mL mark with the water sample.
4. Cap the bottle and shake it vigorously for 15 seconds.
5. Blank: Collect 100 mL of water in a clean, empty bottle.
6. Carry the sample and blank back to the lab.
7. Blend the sample with the high-shear mixer while heating it to the cloud point (~165°F). Allow the sample to cool until the cloudiness totally disappears.
8. Place the sample and blank in separate 10 mL syringes. Place a glass fiber pre-filter and a 0.2 micron cellulose acetate filter on the end of each syringe.
9. Dispense the blank into a glass cuvet with path length of 1 cm.
10. Set the spectrophotometer to a wavelength of 390 nm.
11. Zero the spectrophotometer with the blank.
12. Fill a matching cuvet with the sample and measure its absorbance.
13. Convert the sample's absorbance to oil concentration using the calibration curve created above.



Figure 10. Prepared samples before filtration, Left – Surge 1 Out, 868 mg/L, Right – Surge 2 Out, 431 mg/L. “X” is drawn on the back side of the 1 liter bottles to demonstrate sample clarity.

Figure 11 shows that the absorbance spectrum for a prepared sample compares favorably with the spectrum obtained from oil dissolved in TCE. The elevated absorbance at long wavelength is caused by light scattering from the micellar particles in the microemulsion.

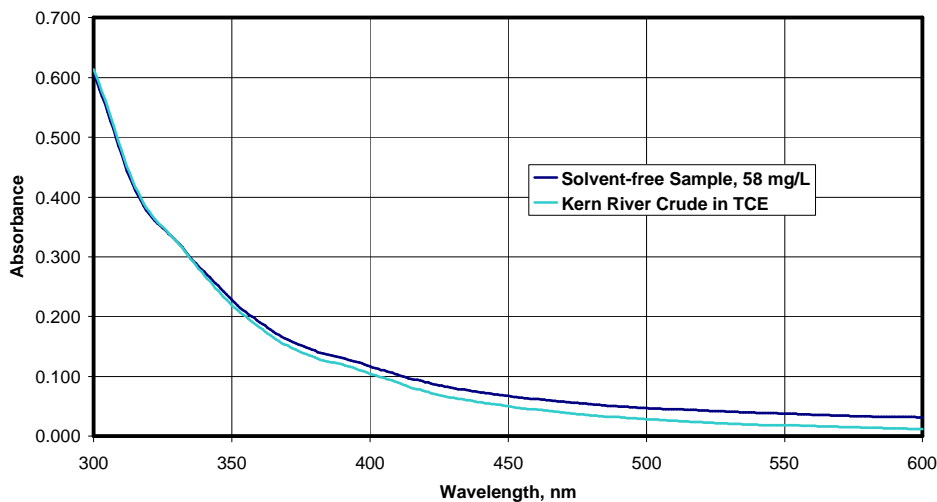

Figure 11. Kern River crude oil spectra.

The method is used at Station 36 to measure total dispersed oil and residual suspended oil (dispersed oil that doesn't float in 5 minutes). The total dispersed oil results are used to track the efficiency of the secondary surge tanks, and to determine the dispersed oil content of water entering the flotation cells. Residual suspended oil results give operators an idea of the severity of reverse emulsions.

Figure 12 shows a recent application of the method to determine the benefit of educting gas into the water entering the secondary surge tanks.

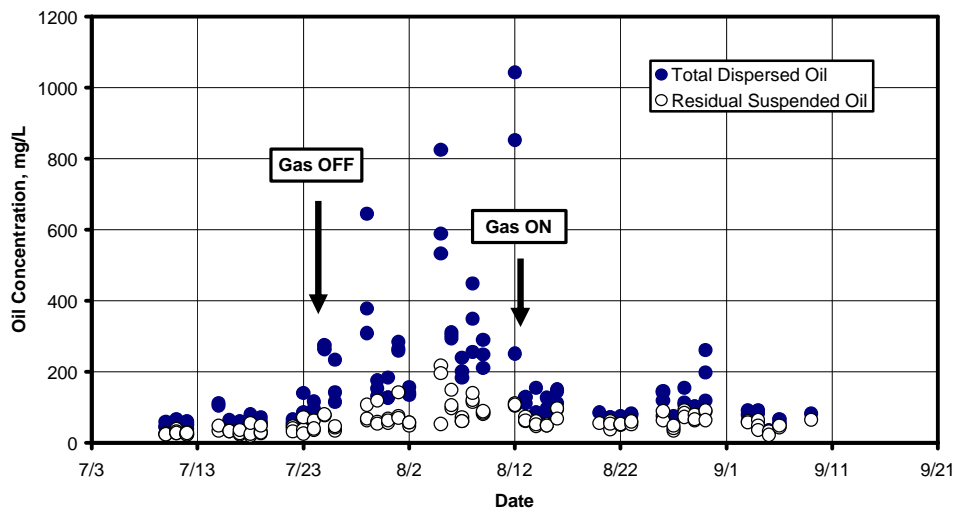

Figure 12. Effect of educted gas on oil content at effluent of Surge 2.

Shortly after the gas was turned off, dispersed oil concentration at the outlet of the tank became very erratic, reaching levels in excess of 1000 mg/L. Residual suspended oil also increased significantly. When the gas was restored, both types of dispersed oil returned to normal levels.